

Litronic-WMS

Reliable Water Content Measuring System



LIEBHERR

Water content, pressure and temperature

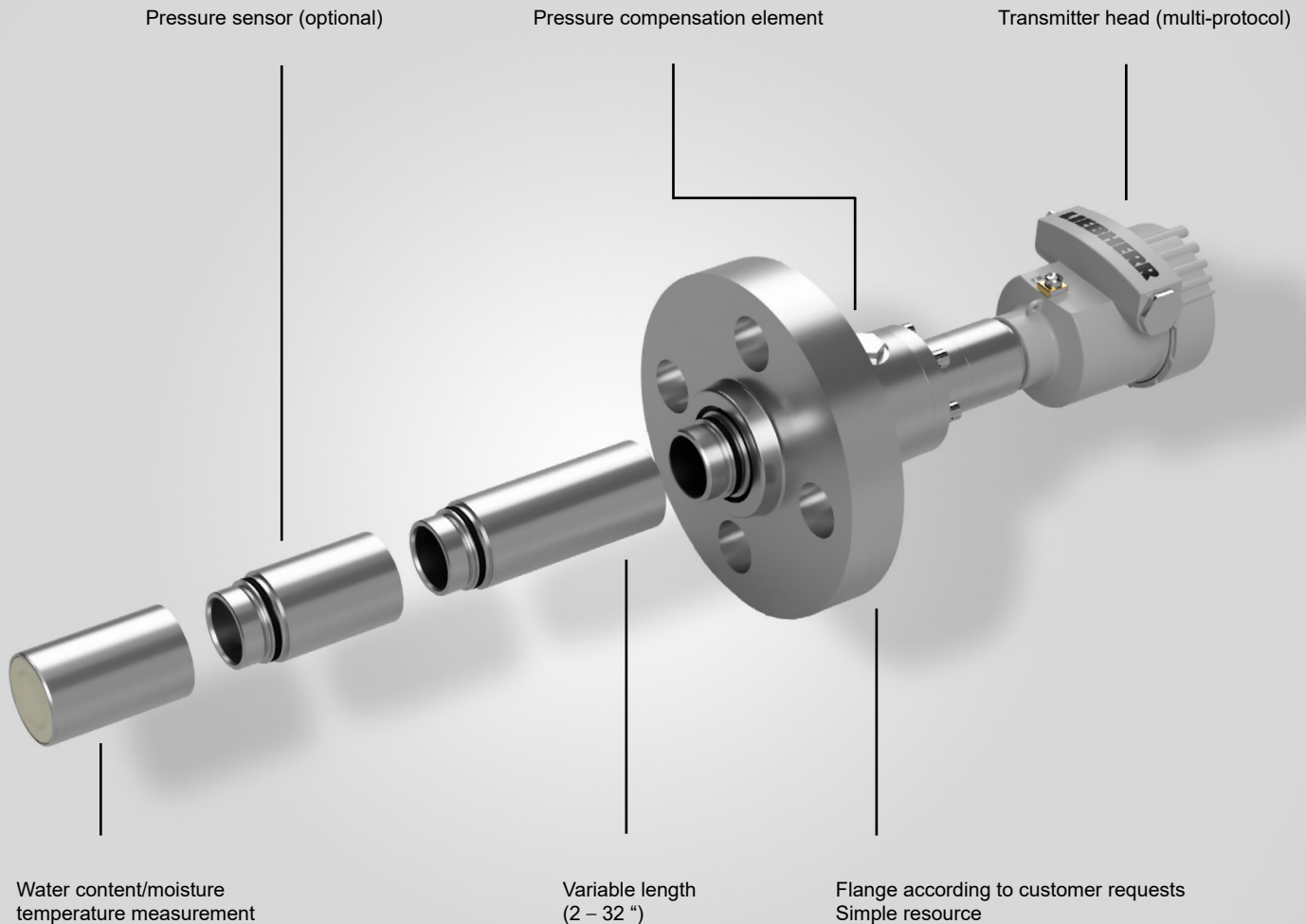

The modular system for monitoring pipelines, tanks and refineries

An autonomous stand-alone-system for the exact determination of water content/moisture, pressure and temperature in a running process. The modular system allows customization to required needs. Highest quality and safety are guaranteed by the system during production, processing and refinement of most of all emulsions, powder and bulks. The Litronic-WMS will meet your demands in any case. The easy-to-use PC software "WIO" enables a quick and exact calibration of concerning measuring points.



Features:

- Adjustable measuring range
- Switch over to other material curves
- Sensor replacement without recalibration
- Temperature compensation
- Adjustable limit signals
- Measured value display (optional)
- Pressure and temperature measurement (optional)
- Usable as interface detector
- Transmitter head multi-protocol: 4-20 mA, HART, Profibus PA, Modbus RTU
- Intrinsically safe and non-intrinsically safe cabling possible

Applications:

- Oil, crude oil, diesel, bio diesel, hardness oil
- Water cut meter
- Lubrication oil, coolant
- Colour, paint, solvent, ethanol
- Wax, resin
- Other emulsions and suspensions



WMS Shaft Sensor P45-GD

- For pipelines and tanks
- For emulsions
- Up to 100 bar
- Variable length's (2 – 32 ")
- Radial measurement field, optional: axial
- Wearing protection: PEEK

WMS Planar Sensor P45-GD

- Planar sensor D = 45 mm
- For emulsions, powder and bulks (e.g.: dust)
- From 2 " pipe diameter
- Up to 100 bar
- Wearing protection: PEEK

WMS Planar Sensor P78-GD

- Planar sensor D = 78 mm
- For powder, bulks and emulsions
- Up to 80 bar
- Wearing protection: Zirconium Oxide Ceramics

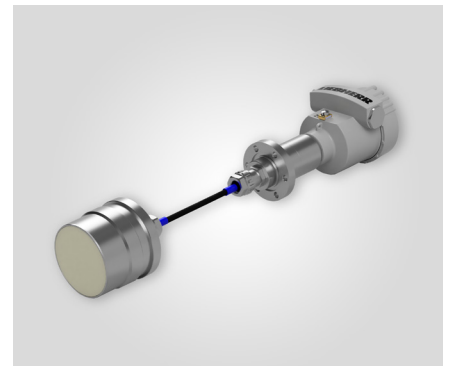
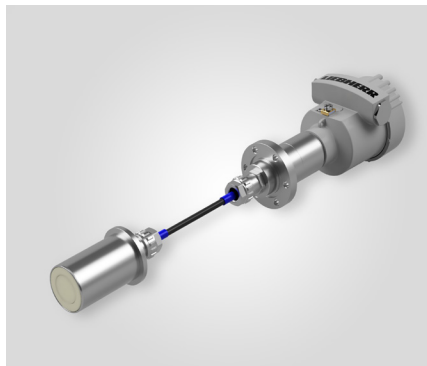

Technical Data

Litronic-WMS	Data
Field frequency:	22 MHz
Physical principle:	Capacity determination with high-frequency leakage field
Adjustable measuring range:	0 – 1 % .. 100 %
Capacity resolution:	100 x 10 ⁻¹⁸ F
Cycle of up-date:	65 ms
Power supply:	24 V, 150 mA DC
Temperature measurement:	-10 – 90 °C
Analogue output:	4 – 20 mA, active
Fault indication:	3,6 mA / 22 mA
Remote parametrization:	HART®-MODEM, Profibus PA
Max. cable length:	1000 m
Protection class:	IP 65
Measured value display:	LCD-Display VEGADIS 82
Resolution display:	10 ppm
Operation temperature:	5 – 80 °C
Material transmitter head:	Aluminium
Material sensor:	1.4571, optional Hastelloy C-276 2.4819
Material retractable fitting:	1.4571
Pressure measurement (optional):	Relative up to 40 bar

Certificates:

ATEX/IECEX: DIN EN IEC 60079-0, 60079-11

US/Canada:

UL/CSA 61010-1; UL/CSA 60079-0; 60079-11
Class I, Division 1, Groups A-D; Class I, Zone 0

Further certificates upon request.

In accordance with regional requirements and regulations.

Ex-Schutz Gas:

II 1/2 G Ex ia IIC T6 Ga*

Ex-Schutz Staub:

II 1/2 D Ex ia IIIC 85°C Da*

*subject to type approval.

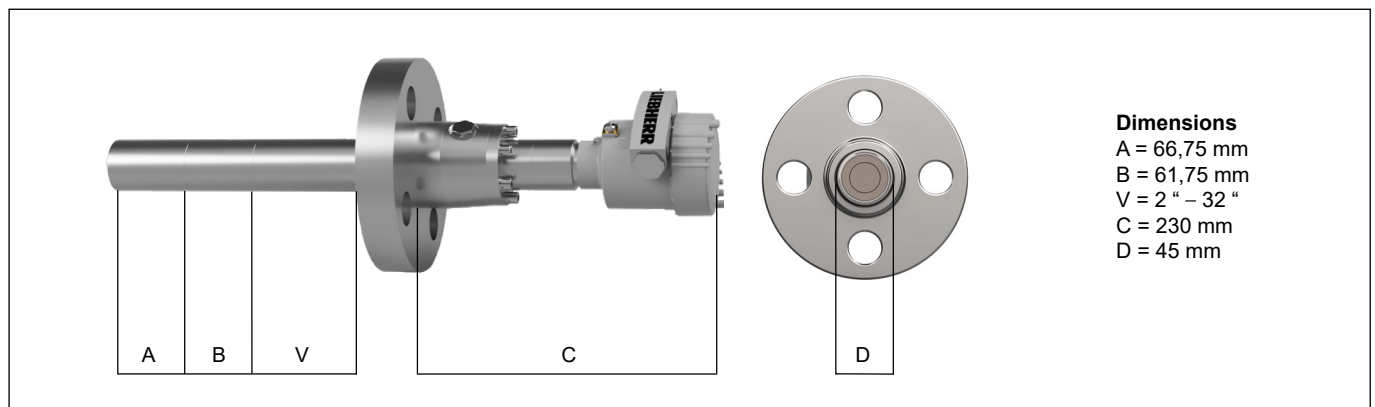

Retractable fitting (Option)

For pipeline diameters from 6 " to 32 " and for tank installations is an optional retractable fitting available. This equipment allows to retract the sensor under process conditions up to 6 bar.

